



Instruction Manual



Food Processor

TT-FP800

www.zline-world.com

■ **SAFETY INSTRUCTIONS**

Read the operating instructions carefully before putting the appliance into operation and keep the instructions for future reference.

- This appliance is for household use only.
- Never dip machine into any liquid and sharp edges. Do not use the appliance with wet hands. If the appliance is humid or wet, unplug it immediately.
- Avoid children or other people who do not know the operation of this machine to use it, unless they are under proper instruction. This appliance is not intended for use by persons (including children) with reduced physical, sensory or mental capabilities, or lack of experience and knowledge, unless they have been given supervision or instruction concerning use of the appliance by a person responsible for their safety.
- Always disconnect the machine from the supply if it is left unattended and before assembling, disassembling or cleaning.
- If the supply cord is damaged, it must be replaced by the manufacture of its service agent or a similar qualified person in order to avoid a hazard.
- Keep your finger away from moving parts and fitted tools .Never put your fingers etc in hinge mechanism.
- Use only original spare parts.
- In order to ensure your children's safety, please keep all packaging (plastic bags, boxes, polystyrene etc.) out of their reach.
- Do not interfere with any safety switches.
- Place the machine on a smooth, flat and stable working surface.

- Be very careful when you handle the blades or inserts. Be especially careful when you remove them from machine, their cutting edges are very sharp.
- Wait until moving parts stop running before you remove the lid of machine.
- Do not exceed the maximum content indicated on the accessories.

■ **BEFORE CONNECTING TO POWER**

- Before connecting to the power, recheck the type of supply and the mains voltage match with the details given on the rating label on the appliance.
- Using for the first time, rip off all wrapping paper and plastic bags. Clean the fittings.

■ **SAVE THESE INSTRUCTIONS**

■ **2 SPEED REGULATOR & PULSE SPEED**

- After settle down the parts you need, If you want the food processor move slowly, turn the adjustment for “1” level.
- If you need the food processor move fast, turn the adjustment for “2” level.
- Use pulse switch for a faster speed. Stop the pulse switch to stop the motor.

■ **USING THE KNIFE BLADE**



The 2 knife blades could be the most versatile of all the attachments.

For Stainless Steel Knife Blade:

- ▲ Before processing, cut the food into pusher size pieces.
- ▲ Not allow to working more than 3 min. per time, cool the motor to cool before the next operation with 30 min. at least.
- ▲ For coarser foods use the pulse control.

Food	Processing size	Quantity	Processing time	Speed
Onion	Into 4 pcs Without skin	100g	approx. 20-40 sec.	Pulse
Garlic	Without skin	100g	approx. 30-60 sec.	Pulse
Carrot	< 2x2 cm	100g	approx. 30-60 sec.	Speed 2/ Pulse
Meat	< 2x2 cm without bone	100g	approx. 20-40 sec.	Speed 2/ Pulse

For Plastic Knife Blade:

- ▲ Not allow to working more than 2 min. per time, cool the motor to cool before the next operation with 30 min. at least.

Food	Suggest quantity		Processing time	Speed
Flour / water	Flour water	100g 60g	approx. 50-90 sec.	Speed 1
Mixing of cake batter	Eggs Margarine Sugar Flour Baking powder	1 pcs 50g 50g 50g 1g	approx. 2 min.	Speed 1

- Follow below flow pictured step by step to assemble machine.
- Ensure the bowl in step 2 and the lid in step 5 are locked well, or the machine will not work.
- In step 3, Stainless Steel knife blade or Plastic blade could be settled, sure either blade is fixed well on shaft.

- After operation, you can disassemble machine by opposite flow and direction.
- Only open the lid when blades completely stopped

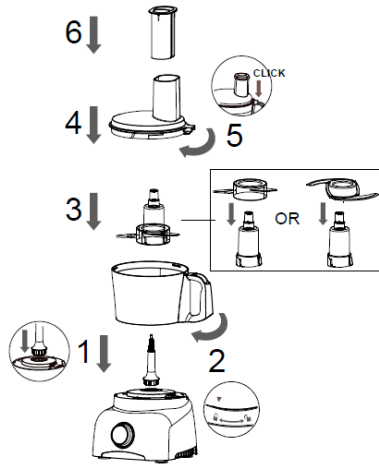

■ **USING SLICER / JULIENNE / FRENCH FRIED POTATO
BLADE**



- ▲ Please pay attention to the capacity line of container. Once the food approaches the max line on the container, please stop operation and pour out food.
- ▲ Switch on and push down evenly with the Pushers - never put your fingers in the feed tube.
- ▲ Do not work more than 3 min., Allow the motor to cool before the next operation at least 30 min.

Julienne Blade

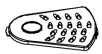

Slicer Blade



French Fried Potato Blade

Food	Suggest quantity	Processing time	Speeds		
			Julienne Disc	Slicer Disc	French Fried Potato Disc
Carrot	200g	approx. 30-60 sec.	Speed 1	Speed 1	N/A
Potato	200g	approx. 30-60 sec.	N/A	N/A	Speed 2
Zucchini	200g	approx. 30-60 sec.	N/A	Speed 1	N/A
Leek	200g	approx. 30-60 sec.	N/A	Speed 1	N/A
Beetroot without skin	200g	approx. 30-60 sec.	N/A	Speed 1	N/A

To get the best performance, follow above suggestion on the speeds.

For Julienne blade, it is suggested on speed 1.

For Shred blade, it is suggested on speed 1

For French Fried Potato blade, it is suggested on speed 2

1. Follow the flow pictured step by step to assemble machine.
2. Ensure the bowl in step 2 and the lid in step 5 are locked well, or the machine will not work.
3. In step 3, 3 type blades could be settled, sure either blade is fixed well on blade holder.
4. After operation, you can disassemble machine by opposite flow and direction.
5. Always be careful when handling the blade as they are very sharp.
6. Only open the lid when the blades are completely stopped

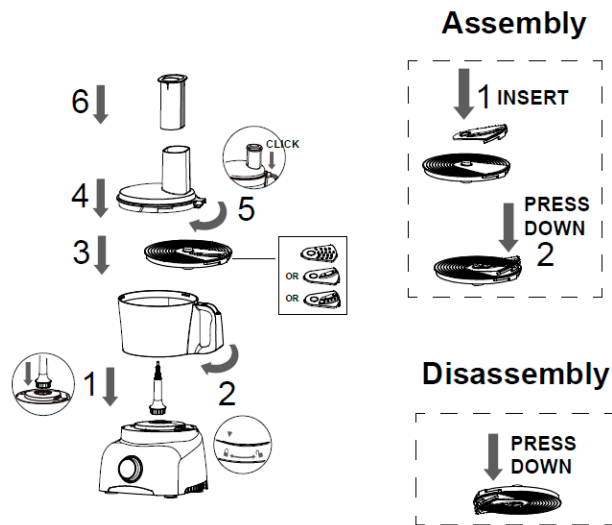

■ USING THE CITRUS JUICER



Use this citrus juicer to squeeze the juice from citrus fruits (e.g. oranges).

- ▲ Pay attention to the capacity line. Once the food approaches the max line on the container, please stop operation and pour out food.
- ▲ Do not work more than 3 min., Allow the motor to cool before the next operation at least 30 min.
- ▲ To get the best performance, press the orange not only vertical but also on left or right side.

1. Follow the flow pictured step by step to assemble machine.
2. Ensure the bowl in step 2 and the juicer in step 3 are locked well, or the machine will not work.

3. After operation, you can disassemble machine by opposite flow and direction.
4. Only take the juicer from the machine when the juicer is completely stopped

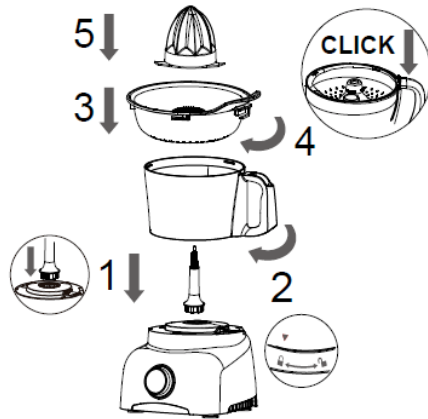

■ USING THE EMULSIFYING DISC



- ▲ Do not work more than 2 min., Allow the motor to cool before the next operation at least 30 min.
- ▲ Use for aioli, instant pudding, mayonnaise, whipping cream, whisking eggs, egg whites, and sponge cake mixtures.
- ▲ For egg white whisking, please use room temperature eggs. Please ensure the bowl and emulsifying disc is dry and free from grease.
- ▲ Clean the emulsifying disc after each use.

Ingredients	Quantity	Processing time	Speed
Whisking cream	100 ml	approx. 10-20 sec.	Speed 2
Egg white	3 eggs	approx. 1-3 min.	Speed 2

1. Follow the flow pictured step by step to assemble machine.
2. Ensure the bowl in step 2 and the lid in step 5 are locked well, or the machine will not work.
3. After operation, you can disassemble machine by opposite flow and direction.
4. Only take the disc from the machine when the disc is completely Stopped

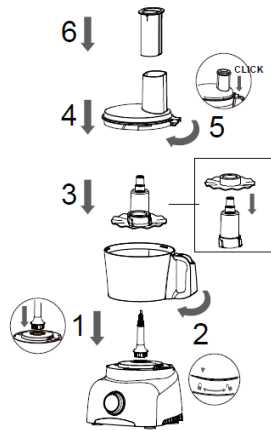

■ CLEANING

- Before cleaning please remove the power cord from the socket.
- Do not immerse the housing with motor in water.
- Do not use any abrasive detergents.
- Please only use a damp to clean the outside of the housing.
- Components that have come into contact with food can be cleaned in soapy water.
- Allow the parts to dry thoroughly before reassembling the device.

■ PROPER DISPOSAL



This product contains recyclable materials.
Do not dispose this product as unsorted municipal waste. Please contact your local municipality for the nearest collection point.

■ **TROUBLESHOOTING**

PROBLEM	EASY SOLUTION
Machine does not work	<ul style="list-style-type: none"> * There is a safety interlock switch on processing bowl / blender. Please sure bowl and lock are securely locked into position. * If the motor still will not start, check the power cord and power outlet.
French Fried Potato Julienne Disk	<ul style="list-style-type: none"> * Always clear any blocked potato from the chipper disc before processing more potatoes.
Some food remains on the disc after processing	<ul style="list-style-type: none"> * It is normal for small pieces to remain after processing.
Motor slows down when mixing dough	<ul style="list-style-type: none"> * Amount of dough may exceed maximum capacity. Remove half and process in two batches.
Dough is too dry	<ul style="list-style-type: none"> * Running machine and add water through feed cube, 1 tablespoon at a time until dough cleans the inside of the processing bowl.
Dough is too wet	<ul style="list-style-type: none"> * Running machine and add flour through feed cube, 1 tablespoon at a time until dough cleans the inside of the processing bowl.
Motor slow down when chopping blade	<ul style="list-style-type: none"> * Amount of meat may be too much. Remove half and process in two batches. * For the best result, trim the meat of fat before processing.
Vibrates/moves during processing	<ul style="list-style-type: none"> * Clean and dry the rubber feet at the bottom of the unit. * Also make sure that the maximum load capacity is not being exceeded.