 **TurboTronic**  
Kitchen Electronics

# *electromix*

## FOOD PROCESSOR

### FOOD PROCESSOR INSTRUCTION MANUAL



**TT-FP900**

[www.zline-world.com](http://www.zline-world.com)







Thank you for choosing:

**Electromix** Food Processor by **TurboTronic®**.

TT-FP900 Makes a bold statement on your kitchen counter.

This food processor is the perfect combination of stunning style and extraordinary performance. This versatile appliance has an attachment for every need whether you're chopping, slicing, beating or even creaming. Being the perfect sous chef, the Electromix Food Processor is designed to take care of the more mundane tasks of cooking so you have more time to enjoy the parts you really love. Whether you need to chop up some chunky vegetables for a casserole or you need a little help finely slicing up ingredients to sneak into your little one's Spaghetti Bolognese – this food processor will bring ease to every meal you make at home.

**Save this instruction  
For Household Use Only!**

	Indicates to read and review instructions to understand operation and use of product.
	Indicates the presence of a hazard that can cause personal injury, death or substantial property damage if the warning included with this symbol is ignored.
	Take care to avoid contact with hot surface. Always use hand protection to avoid burns.
	For indoor and household use only.

## **SAFETY INSTRUCTIONS**

Read the operating instructions carefully before putting the appliance into operation and keep the instructions for future reference.

- This appliance is for household use only.
- Never dip machine into any liquid.
- Do not use the appliance with wet hands. If the appliance is humid or wet, unplug it immediately.
- Avoid children or other people who do not know the operation of this machine to use it, unless they are under proper instruction. This appliance is not intended for use by persons (including children) with reduced physical, sensory or mental capabilities, or lack of experience and knowledge, unless they have been given supervision or instruction concerning use of the appliance by a person responsible for their safety.
- Always disconnect the machine from the supply if it is left unattended and before assembling, disassembling or cleaning.
- If the supply cord is damaged, it must be replaced by the manufacture of its service agent or a similar qualified person in order to avoid a hazard.
- Keep your finger away from moving parts and fitted tools.
- Never put your fingers etc in hinge mechanism.
- Use only original spare parts.
- In order to ensure your children's safety, please keep all packaging (plastic bags, boxes, polystyrene etc.) out of their reach.
- Do not interfere with any safety switches.
- Place the machine on a smooth, flat and stable working surface.

- Be very careful when you handle the blades or inserts. Be especially careful when you remove them from machine, their cutting edges are very sharp.
- Wait until moving parts stop running before you remove the lid of machine.
- Do not exceed the maximum content indicated on the accessories.

## **BEFORE CONNECTING TO POWER**

- Before connecting to the power, recheck the type of supply and the mains voltage match with the details given on the rating label on the appliance.
- Using for the first time, rip off all wrapping paper and plastic bags. Clean the fittings.

## **SAVE THESE INSTRUCTIONS 2 SPEED REGULATOR & PULSE SPEED**

- After settle down the parts you need, if you want the food processor move slowly, turn the adjustment for “1” level.
- If you need the food processor move fast, turn the adjustment for “2” level.
- Use pulse switch for a faster speed. Stop the pulse switch to stop the motor.

## **USING THE KNIFE BLADE**

The 2 knife blades could be the most versatile of all the attachments.



## FOR STAINLESS STEEL KNIFE BLADE:

- Before processing, cut the food into pusher size pieces.
- Not allow to working more than 3 min. per time, cool the motor to cool before the next operation with 30 min. at least.
- For coarser foods use the pulse control.

Food	Processing size	Quantity	Processing time	Speed
Onion	Into 4 pcs Without skin	250g	approx. 30-60 sec.	Pulse
Garlic	Without skin	250g	approx. 30-60 sec.	Pulse
Carrot	< 2x2 cm	250g	approx. 30-60 sec.	Speed 2/ Pulse
Meat	< 2x2 cm without bone	250g	approx. 30-60 sec.	Speed 2/ Pulse

## FOR PLASTIC KNIFE BLADE:

- Not allow to working more than 2 min. per time, cool the motor to cool before the next operation with 30 min. at least.

Food	Suggest quantity		Processing time	Speed
Flour / water	Flour	100g	approx. 90 sec.	Speed 1
	water	65g		
Mixing of cake batter	Eggs	1 pcs	approx. 2 min.	Speed 1
	Margarine	50g		
	Sugar	50g		
	Flour	50g		
	Baking powder	1g		

- Follow below flow pictured step by step to assemble machine.
- Ensure the bowl in step 2 and the lid in step 5 are locked well, or the machine will not work.
- In step 3, Stainless Steel knife blade or Plastic blade could be settled, sure either blade is fixed well on shaft.
- After operation, you can disassemble machine by opposite flow and direction.
- Only open the lid when blades completely stopped

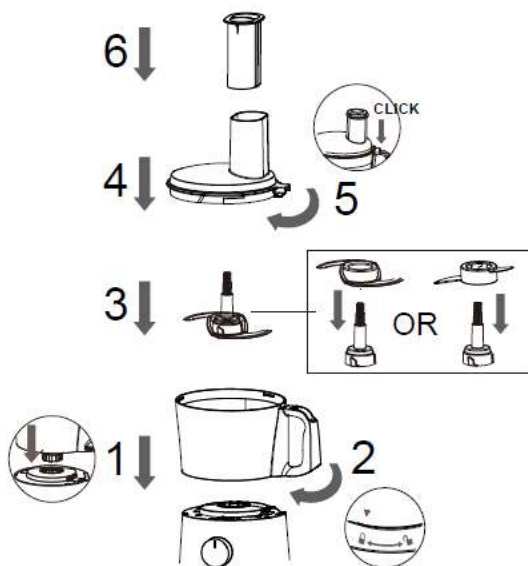

## USING SLICER / JULIENNE / FRENCH FRIED POTATO / SHRED BLADE



Please pay attention to the capacity line of container. Once the food approaches the max line on the container, please stop operation and pour out food.

- Switch on and push down evenly with the Pushers - never put your fingers in the feed tube.
- Do not work more than 3 min per time., Allow the motor to cool before the next operation at least 30 min.



Julienne Blade



Slicer Blade



French Fried Potato Blade

Food	Suggest quantity	Processing time	Speeds		
			Julienne Disc	Slicer Disc	French Fried Potato Disc
Carrot	500g	approx. 1 min.	Speed 1	Speed 2	N/A
Potato	500g	approx. 1 min.	N/A	N/A	Speed 2
Zucchini	500g	approx. 1 min.	N/A	Speed 2	N/A
Leek	500g	approx. 1 min.	N/A	Speed 2	N/A
Beetroot without skin	500g	approx. 1 min.	N/A	Speed 2	N/A

To get the best performance, follow above suggestion on the speeds.

For Julienne blade, it is suggested on speed 1.

For Slicer blade, it is suggested on speed 2

For French Fried Potato blade, it is suggested on speed 2

1. Follow the flow pictured step by step to assemble machine.
2. Ensure the bowl in step 2 and the lid in step 6 are locked well, or the machine will not work.
3. In step 4, 3 type blade could be settled, sure either blade is fixed well on blade holder.
4. After operation, you can disassemble machine by opposite flow and direction.
5. Always be careful when handling the blade as they are very sharp.
6. Only open the lid when the blades are completely stopped

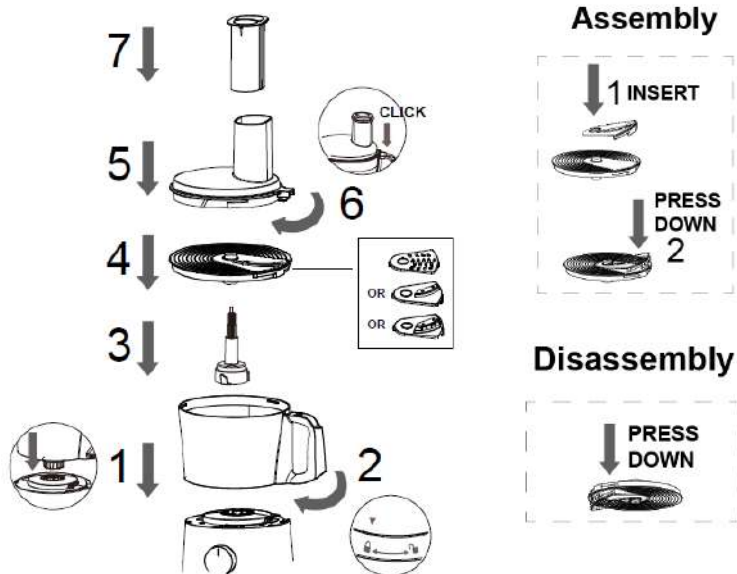

## USING THE EMULSIFYING DISC



Use for aioli, instant pudding, mayonnaise, whipping cream, whisking eggs, egg whites, and sponge cake mixtures.

\* Please do not use to prepare cake mixtures with butter or margarine or to knead dough.

\* For egg white whisking, please use room temperature eggs.

Please ensure the bowl and emulsifying disc is dry and free from grease.

\* Clean the emulsifying disc after each use.

- Do not use the machine for more than 3 minutes at a time. Allow the motor to cool down for at least 30 minutes before the next operation.

1. Follow the flow pictured step by step to assemble machine.
2. Ensure the bowl in step 2 and the lid in step 6 are locked well, or the machine will not work.
3. After operation, you can disassemble machine by opposite flow and direction.
4. Only take the disc from the machine when the disc is completely Stopped

To keep the best processing result: **use the Max. speed**

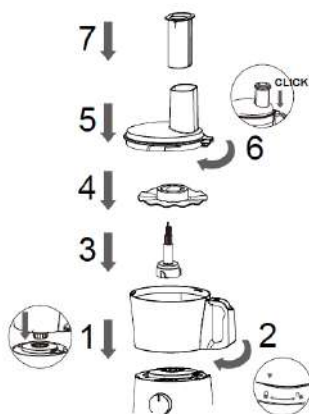

## USING THE CITRUS JUICER

Use this citrus juicer to squeeze the juice from citrus fruits (e.g. oranges).



- Pay attention to the capacity line. Once the food approaches the max line on the container, please stop operation and pour out food.
  - Do not work more than 3 min. per time, Allow the motor to cool before the next operation at least 30 min.
  - To get the best performance, press the orange not only vertical but also on left or right side.
1. Follow the flow pictured step by step to assemble machine.
  2. Ensure the bowl in step 2 and the juicer in step 5 are locked well, or the machine will not work.
  3. After operation, you can disassemble machine by opposite flow and direction.
  4. Only take the juicer from the machine when the juicer is completely stopped

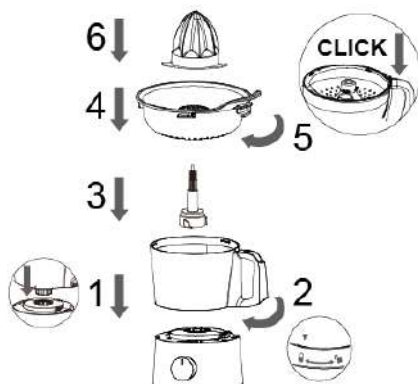

## USING THE BLENDER



- Do not work more than 2 min., Allow the motor to cool before the next operation at least 30 min.
  - Never open the lid when the blade is still rotating. For extra caution, you can unplug the appliance before removing the lid.
  - To add liquid ingredients during processing, remove the measuring cup of the lid and pour liquid through the opening in the lid.
  - Cut solid ingredients into smaller pieces before you process them.
  - For a large quantity, pour small batches of ingredients instead of a large quantity at one time.
  - Use cooked ingredients for a soup preparation.
  - If a liquid is hot or tends to foam (e.g. milk), do not put more than 1 liter in the blender jar to avoid spillage.
  - If the result is not satisfactory, switch the appliance off and stir the ingredients with a spatula.
  - To keep the best processing result: **use the Max. or Pulse speed.**
1. Follow the flow pictured step by step to assemble machine.
  2. Ensure the jar in step 2 locked well, or the machine will not work.
  3. After operation, you can disassemble machine by opposite flow and direction.
  4. Always be careful when handling the stainless-Steel blade as they are very sharp.
  5. Only open the lid when the blades are completely Stopped



## CLEANING

- Before cleaning please remove the power cord from the socket.
- Do not immerse the housing with motor in water.
- Do not use any abrasive detergents.
- Please only use a damp to clean the outside of the housing.
- Components that have come into contact with food can be cleaned in soapy water.
- Allow the parts to dry thoroughly before reassembling the device.

## PROPER DISPOSAL



This product contains recyclable materials.

Do not dispose this product as unsorted municipal waste. Please contact your local municipality for the nearest collection point.

## TROUBLESHOOTING

PROBLEM	EASY SOLUTION
Machine does not work	<ul style="list-style-type: none"> <li>* There is a safety interlock switch on processing bowl / blender. Please sure bowl and lock are securely locked into position.</li> <li>* If the motor still will not start, check the power cord and power outlet.</li> </ul>
French Fried Potato Julienne Disk	<ul style="list-style-type: none"> <li>* Always clear any blocked potato from the chipper disc before processing more potatoes.</li> </ul>
Some food remains on the disc after processing	<ul style="list-style-type: none"> <li>* It is normal for small pieces to remain after processing.</li> </ul>
Motor slows down when mixing dough	<ul style="list-style-type: none"> <li>* Amount of dough may exceed maximum capacity. Remove half and process in two batches.</li> <li>* Do not add more than 250g dough.</li> </ul>

Dough is too dry	* Running machine and add water through feed cube, 1 tablespoon at a time until dough cleans the inside of the processing bowl.
Dough is too wet	* Running machine and add flour through feed cube, 1 tablespoon at a time until dough cleans the inside of the processing bowl.
Motor slow down when chopping blade	* Amount of meat may be too much. Remove half and process in two batches. * For the best result, trim the meat of fat before processing.
Vibrates/moves during processing	* Clean and dry the rubber feet at the bottom of the unit. * Also make sure that the maximum load capacity is not being exceeded.

## DISPOSAL OF OLD ELECTRICAL APPLIANCES



The European directive 2002/96/EC on Waste Electrical and Electronic Equipment (WEEE), requires that old household electrical appliances must not be disposed of in the normal unsorted municipal waste stream. Old appliances must be collected separately in

order to optimize the recovery and recycling of the materials they contain, and reduce the impact on human health and the environment. The crossed out “wheeled bin” symbol on the product reminds you of your obligation, that when you dispose of the appliance, it must be separately collected.

Consumers should contact their local authority or retailer for information concerning the correct disposal of their old appliance.

## LIMITED WARRANTY

Limited Warranty applies to purchases made from authorized retailers of **TurboTronic®**.

**TurboTronic®** Warranty coverage applies to the original owner and to the original product only and is not transferable.

**TurboTronic®** warrants that the unit shall be free from defects in material and workmanship. Limited Warranty apply only when it is used under normal household conditions and maintained according to the requirements outlined in the Owner's Guide, subject to the following

conditions and exclusions:

### **What is covered by this warranty?**

1. The original unit and/or non-wearable parts deemed defective, in **TurboTronic®** sole discretion, will be repaired or replaced
2. **TurboTronic®** reserves the right to replace the unit with one of equal or greater value.

### **What is not covered by this warranty?**

1. Normal wear and tear of wearable parts (such as blending vessels, lids, cups, blades, blender bases, removable pots, racks, pans, etc.), which require regular maintenance and/or replacement to ensure the proper functioning of your unit, are not covered by this warranty.
2. Any unit that has been tampered with or used for commercial purposes.
3. Damage caused by misuse, abuse, negligent handling, failure to perform required maintenance (e.g., failure to keep the well of the motor base clear of food spills and other debris), or damage due to mishandling in transit.
4. Consequential and incidental damages.
5. Defects caused by repair persons not authorized by **TurboTronic®**. These defects include damages caused in the process of shipping, altering, or repairing the **TurboTronic®** product (or any of its parts)

when the repair is performed by a repair person not authorized by **TurboTronic®**.

6. Products purchased, used, or operated outside Europe.

Illustrations may differ from actual product.

We are constantly striving to improve our products, therefore the specifications contained herein are subject to change without notice.

**TurboTronic®** and **Z-Line®** are registered trademarks of **Z-GLOBAL B.V.B.A®**

PRINTED IN PRC